



WATER TREATMENT SYSTEMS
**WATER/OIL/SOLIDS
SEPARATORS**
WOS AND WCL SERIES



MAKING A POSITIVE IMPACT ON OUR ENVIRONMENT FOR TODAY AND FUTURE GENERATIONS.

WOS Series

Above-Ground Water/Oil/Solids Separators



WOS-15-0M10 shown with continuous recirculation option, WX-0001

Benefits:

- Capability of handling oil and solids
- Takes up an extremely small footprint
- Easy to maintain

Features:

- Ozone
- Stainless-steel tank
- ETL listed control panel
- 1.0 HP surface-mount sump pump

Certification:

- ETL Certified – US and Canada

Designed to remove free oils from wash water before discharging to a sanitary sewer, the water/oil/solids separators will reduce the amount of suspended solids while removing hydrocarbons.



ETL listed NEMA-4 rated corrosion-proof control panel for safe and reliable operation

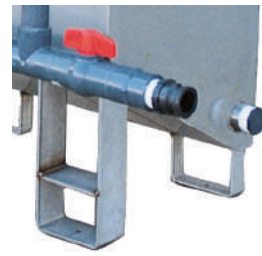

Sloped bottom design for easier solids removal

MODEL NUMBER	FLOW RATE	COALESCING MEDIA	TANK HOLDING CAPACITY	IN-LINE STRAINER PUMP	POWER REQUIREMENTS	DIMENSIONS (LxWxH)	SHIP WT.
WOS-15-0M10	0-15 GPM	672 sq. ft.	170 gallons	1.0 HP, 120V	120V, 1Ø, 15.0A	91x31x40in.	675 lb.
WOS-15-0M30	0-15 GPM	672 sq. ft.	170 gallons	1.0 HP, 230V	208-230V, 3Ø, 5.0A	91x31x40in.	675 lb.
WOS-30-0M10	0-30 GPM	1,152 sq. ft.	340 gallons	1.0 HP, 120V	120V, 1Ø, 15.0A	97x50x44in.	865 lb.
WOS-30-0M30	0-30 GPM	1,152 sq. ft.	340 gallons	1.0 HP, 230V	208-230V, 3Ø, 5.0A	97x50x44in.	865 lb.

ACCESSORIES:

PART NUMBER	DESCRIPTION	FITS MODELS
855-0002	Replacement media – Initial chamber	WOS-15 models
855-0009	Replacement media – Initial chamber	WOS-30 models
855-0010	Replacement media – Main chamber	WOS-15 models
855-0008	Replacement media – Main chamber	WOS-30 models

OPTIONS:

PART NUMBER	DESCRIPTION	FITS MODELS
WX-0001	Continuous recirculation – Recirculates back to the pit to prevent water from becoming stagnant	All models
WX-0057	230V, 1Ø – Upgrades 120V model to operate at 230V	WOS-15-0M10
WX-0058	460V, 3Ø – Upgrades 208-230V model to operate at 460V	WOS-15-0M30
WX-0059	230V, 1Ø – Upgrades 120V model to operate at 230V	WOS-30-0M10
WX-0060	460V, 3Ø – Upgrades 208-230V model to operate at 460V	WOS-30-0M30

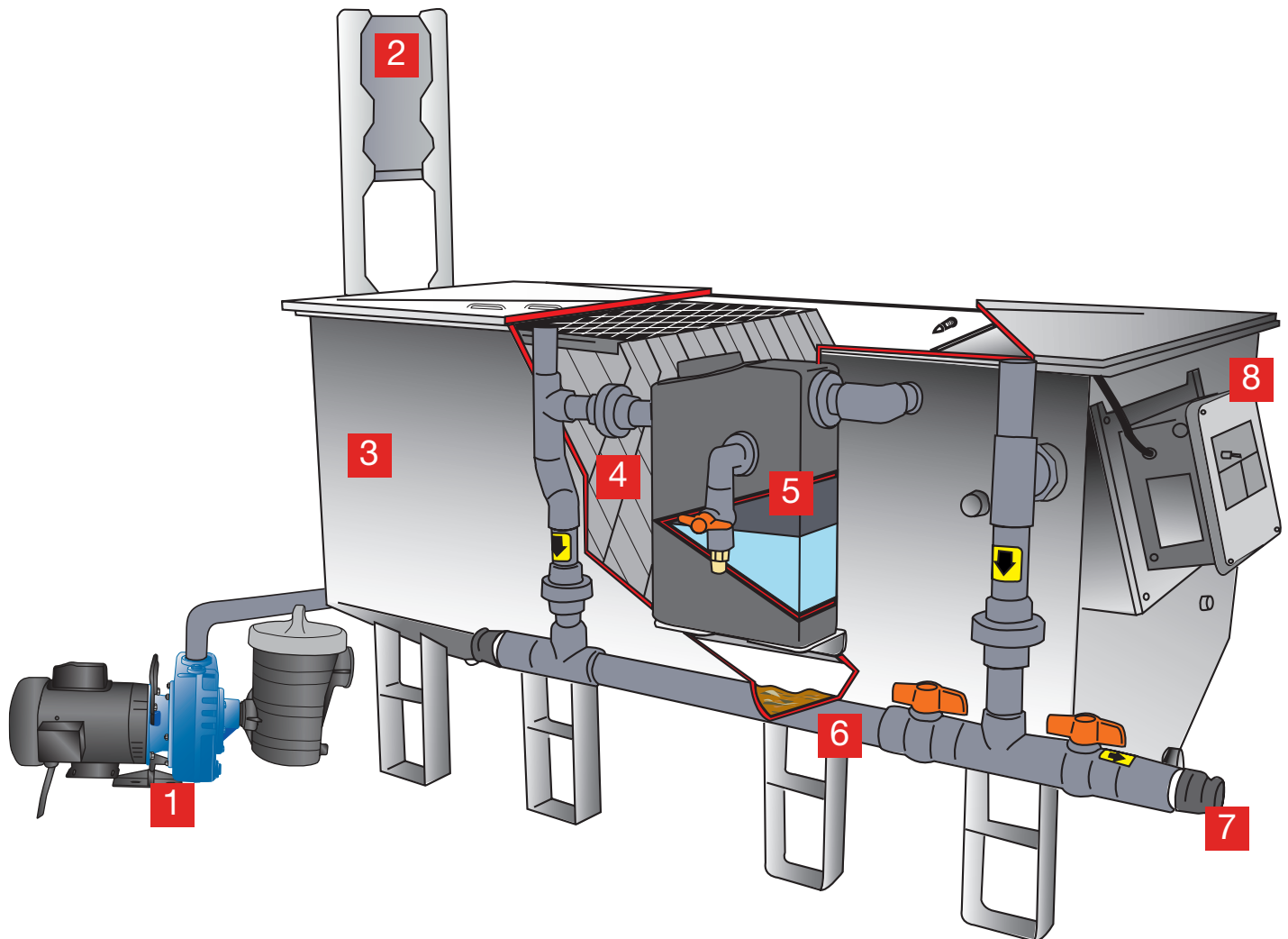

1. **Surface-Mount Sump Pump** – Untreated wash water is introduced into the system via a 1.0 HP surface-mount sump pump, which is included with the system.
2. **Corona Discharge Ozone System** – As the wash water is pumped into the water/oil/solids separator and it is injected with a high concentration of ozone via a corona discharge injector system for a "quick kill" of live bacteria on contact. Ozone also breaks up emulsified oils, allowing them to coalesce and float to the top of the tank for separation into the oil decanter.
3. **Three Stage Stainless-Steel Tank** – As the water flows through the stainless-steel three stage water/oil/solids separator, it changes the overall flow direction several times as it flows around four vertical baffles. The water is slowed down and fine silt and solids drop to the bottom of the tank.
4. **Bio-Film Generative Film** – As the water progresses through hundreds of square-feet of honey-combed-shaped meshed oleophilic (oil-attracting) coalescing media. It will change directions countless times. In this process, mechanically emulsified oil particles are attracted from the water to the oleophilic media and float to the surface.
5. **Oil Skimmer/Decanter** – Once the oil floats to the water's surface, it is then skimmed into an oil decanter for easy disposal.
6. **Sloped Solids Trap** – Fine silt and particles are dropped to the bottom of the sloped stainless-steel tank for easy flushing and disposal.
7. **Discharge Port** – Once the water has been treated, it flows into the final chamber of the stainless-steel tank and then through a 2-inch drain line to a sanitary sewer drain in the floor.
8. **Electrical Control Panel** – ETL listed NEMA-4 rated corrosion-proof control panel for safe and reliable operation.

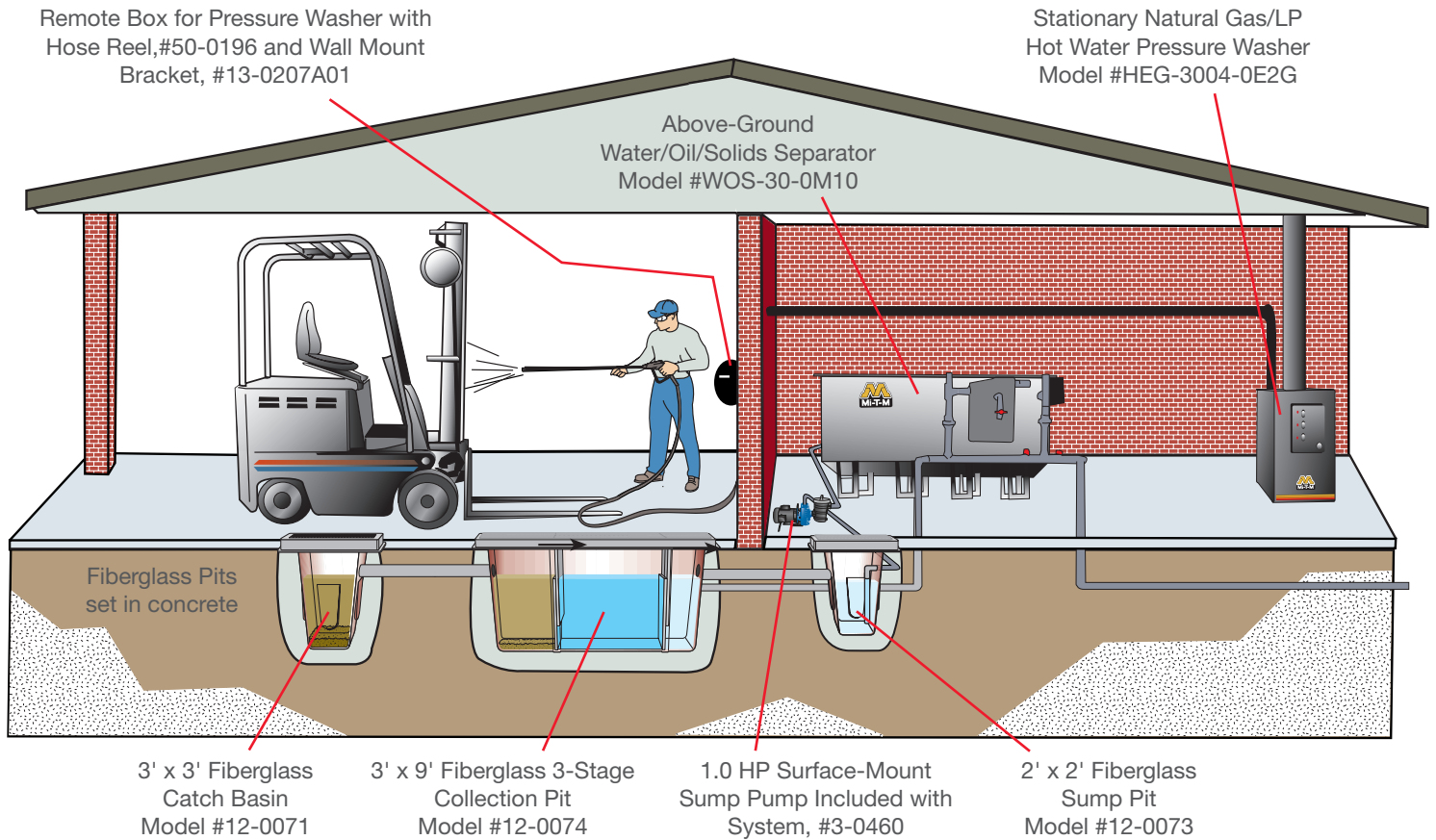

Recommended Applications:

- Rental yards
- Heavy equipment dealers
- Trucking facilities
- Military bases
- Truck rental fleets
- Diesel repair facilities
- Forklift washing operations
- Aircraft maintenance and restoration
- Shipyards
- Municipalities/State DOTs
- Oil fields
- Engine rebuilders and manufacturers

The Importance of a Proper Pit System:

Once equipment is washed, the untreated wash water flows into your pit system. A proper pit system for your application is the first step in proper wash water treatment and a critical element in any wash water recycle system.

Consult Mi-T-M Corporation or your local distributor to determine the pit system configuration that works best for your application.

A clarifier allows for greater settling and removal of accumulated solids in wastewater before treatment. This pretreatment makes it easier for water treatment systems to operate effectively.



ETL listed NEMA-4 rated corrosion-proof control panel for safe and reliable operation (WCL-30D-0M10 only)



Ozone generator for a "quick kill" of live bacteria on contact (WCL-30D-0M10 only)



WCL-30D-0M10

Features:

- A choice between a 300-gallon or 600-gallon cone-shaped tank for effective settling and easy handling of heavy solids
- Solids separation chamber with bag filter and decanting
- Oil skimmer and decanter for easy handling of oil
- ETL listed control panel
- 1.0 HP surface-mount sump pump

Certification:

- ETL Certified – US and Canada

MODEL NUMBER	FLOW RATE	CLARIFIER TANK	OIL COALESCING AREA	POWER REQUIREMENTS	DIMENSIONS (LxWxH)	SHIP WT.
WCL-10S-0M10**	0-10 GPM	300 gallons	48 sq. ft.	230V, 1Ø, 8.0A	48x67x97in.	641 lb.
WCL-30S-0M10**	0-30 GPM	600 gallons	73 sq. ft.	230V, 1Ø, 8.0A	63x75x106in.	725 lb.
WCL-30D-0M10^	0-30 GPM	600 gallons	425 sq. ft.	230V, 1Ø, 13.0A	63x75x106in.	980 lb.

*Float includes 230V plug.
 +Control panel not included.
 ^Ozone is included.

ACCESSORIES:

PART NUMBER	DESCRIPTION	FITS MODELS
855-0015	Treated-water storage tank – 80-gallons, for transferring water to the next process or point of discharge	All models
855-0016	Treated-water storage tank – 165-gallons, for transferring water to the next process or point of discharge	All models
RC-0005-0001	Mazzanine stand – For convenient access to the oil skimmer and to the top portion of the tank	WCL-30 models

1. **Clarifier Tank** – A 300-gallon or 600-gallon cone-shaped clarifier settles solids. Free-floating oils are removed via a suspended oil skimmer. Model WCL-30D-0M10 has 425 sq. ft. of oil coalescing media to help capture mechanically emulsified oil.
2. **Electrical Control Panel** – ETL listed NEMA-4 rated corrosion-proof control panel for safe and reliable operation. (Standard on WCL-30D-0M10)
3. **Corona Discharge Ozone Injection** – For odor control and breaking emulsified oils, the WCL-30D-0M10 comes with a corona discharge ozone generator. The ozone generator has an output of 0.5 grams per hour of ozone for a "quick kill" of live bacteria on contact. Ozone also breaks up emulsified oils, allowing them to coalesce and float to the top of the tank for separation into the oil decanter.
4. **Treated Water Holding Tank** (Accessories #855-0015, 80-gallon capacity and #855-0016, 165-gallon capacity) – Treated water holding tank for transferring water to the next process or point of discharge.
5. **Solids Separation Chamber** – Solids from the wastewater stream settle at the base of the clarifier tank. With the opening of a single valve, solids are easily dropped into a bag filter in the solids separation chamber for effective capture and easy disposal. The bag filter is suspended on a dewatering tray with drainage returning to the in-ground collection pits.
6. **Surface-Mount Sump Pump** – Untreated wash water is introduced into the system via a 1.0 HP surface-mount sump pump, which is included with the system.
7. **Oil Decanter** – Oil skimmed from the surface of the clarifier tank is captured in a conveniently located oil decanter. Oil can be easily removed for appropriate disposal.
8. **Mezzanine Stand**
(Accessory #RC-0005-0001) – A maintenance ladder and platform is available for the WCL-30 Series for convenient access to the oil skimmer and top portion of the tank.

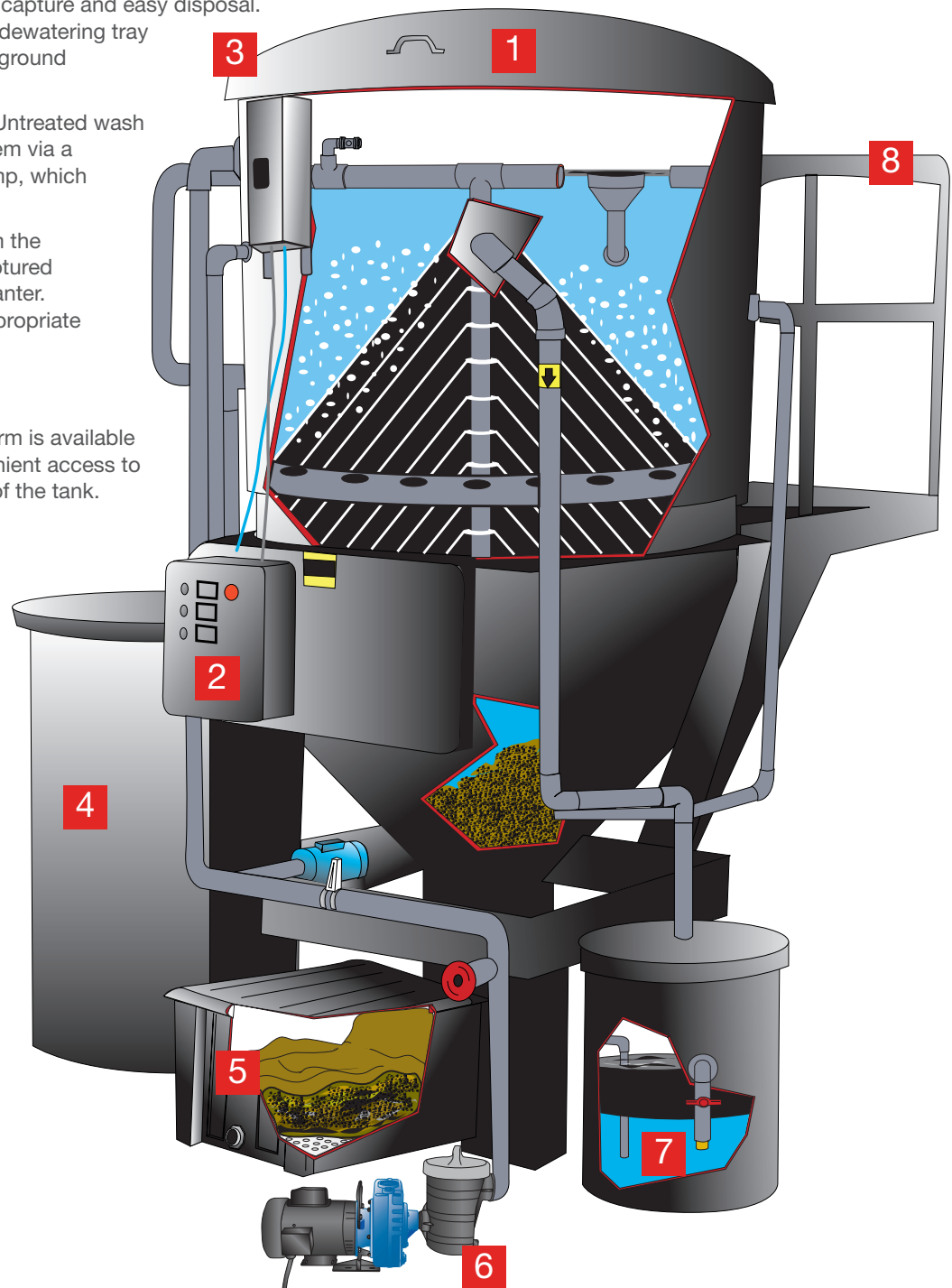

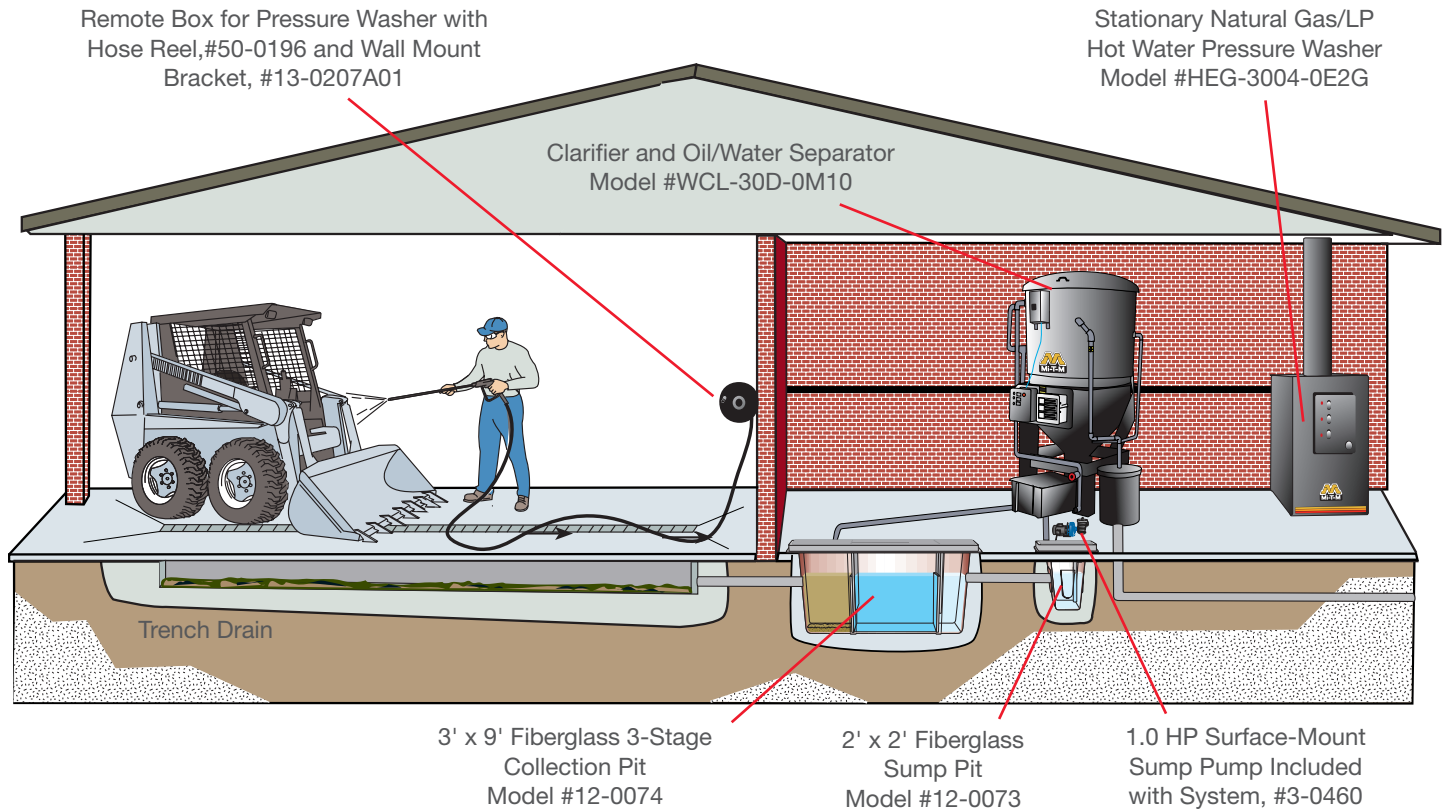

Recommended Applications:

- Rental yards
- Golf courses
- Heavy equipment dealers
- Trucking facilities
- Military bases
- Truck rental fleets
- Diesel repair facilities
- Forklift washing operations
- Aircraft maintenance and restoration
- Shipyards
- Municipalities/State DOTs
- Oil fields
- Engine rebuilders and manufacturers

The Importance of a Proper Pit System:

Once equipment is washed, the untreated wash water flows into your pit system. A proper pit system for your application is the first step in proper wash water treatment and a critical element in any wash water recycle system.

Consult Mi-T-M Corporation or your local distributor to determine the pit system configuration that works best for your application.

WOS and WCL Series

In-Ground Fiberglass Pit Systems

3' x 9' PIT SYSTEMS

PART NUMBER	PIT SIZE (FT.)	DESCRIPTION	SHIP WT.
12-0074	3x9x4.5	3-stage collection pit, fiberglass, 600-gallon capacity	480 lb.
12-0223	3x9x4.5	3-foot x 9-foot baffleless pit, fiberglass, 600-gallon capacity	480 lb.
12-0238	3x9x4.5	2-stage collection pit with single baffle, fiberglass, 600-gallon capacity	480 lb.
12-0244	3x9x4.5	3-stage collection pit with middle weir and third baffle, fiberglass, large solids settling area, 600-gallon capacity	480 lb.
20-1505A18	Fits 3x9	Pit liner assembly, painted; 2 qty. are required	45 lb.
56-0032	Fits 3x9	Aluminum hinged diamond plate cover with 3 frame sections	100 lb.
RC-0001-0003	Fits 3x9	Brace kit for installation of 3-stage collection pit	200 lb.
RC-0018-0001*	Fits 3x9	Steel grating for pit; 3,060 lb./ft. ² uniform load rating	546 lb.
RC-0018-0002*	Fits 3x9	Steel grating for pit with steel cover; 3,060 lb./ft. ² uniform load rating	680 lb.

*May combine RC-0018-0001 and RC-0018-0002 to have both open and closed sections for the 3' x 9' pits.

3' x 3' PIT SYSTEM

PART NUMBER	PIT SIZE (FT.)	DESCRIPTION	SHIP WT.
12-0071	3x3x4.5	Catch basin, fiberglass, 100-gallon capacity	190 lb.
20-0480A18	Fits 3x3	Steel grating for pit, 2 sections; 6,250 lb./ft. ² uniform load rating, H-20 load rated	250 lb.
20-1533A18	Fits 3x3	Pit liner assembly, painted	26 lb.
56-0031	Fits 3x3	Aluminum diamond plate cover and frame	30 lb.
RC-0001-0002	Fits 3x3	Brace kit for installation of 3-foot x 3-foot pit	150 lb.

2' x 2' PIT SYSTEM

PART NUMBER	PIT SIZE (FT.)	DESCRIPTION	SHIP WT.
12-0073	2x2x3	Sump pit, fiberglass, 50-gallon capacity	92 lb.
20-0479A18	Fits 2x2	Steel grating for pit; 6,660 lb./ft. ² uniform load rating, H-20 load rated	100 lb.
56-0030	Fits 2x2	Aluminum diamond plate cover and frame	60 lb.
RC-0001-0001	Fits 2x2	Brace kit for installation of 2-foot x 2-foot pit	75 lb.

Additional product information available in the Pit Systems Brochure.



www.mitm.com
 50 Mi-T-M Drive • Peosta, IA 52068
 ph 800-553-9053 • fax 563-556-1235
 corp@mitm.com

Distributed by:



WARNING: Cancer and Reproductive Harm - www.P65warnings.ca.gov.